

Installation, Operation and Maintenance Instructions

1200°C Cupellation Furnace - CF Model: 60B
No Controller

CF 60B + No Controller

Contents

This manual is for guidance on the use of the Carbolite Gero product specified on the front cover. This manual should be read thoroughly before unpacking and using the furnace or oven. The model details and serial number are shown on the back of this manual. Use the product for the purpose for which it is intended.

1.0	Symbols and Warnings	4
1.1	Switches and Lights	4
1.2	General Warnings	4
1.3	Prerequisites to Use	5
2.0	Installation	6
2.1	Unpacking & Handling	6
2.2	Door Counterbalance	6
2.3	Siting and Setting Up	7
2.4	Heating Elements	8
2.5	Electrical Connections	8
3.0	Temperature Controller	10
4.0	Time Switch	11
4.1	Digital Time Switch - Theben TR 635 top2	11
	Important Note	12
	Reset	12
	Setting the Time and Date (and Daylight Saving Rules)	12
	Setting a Switch-On or Switch-Off Time	12
	Modifying or deleting a Switch-On or Switch-Off Time	12
	Overriding the Program	13
	Pulse and Cycle	13
5.0	Operation	14
5.1	Operating Cycle	14
5.2	Instrument Layout	15
5.3	General Operating Advice	15
5.4	Operator Safety	15
5.5	Over-Temperature Control (if fitted)	16
6.0	Maintenance	17
6.1	General Maintenance	17
6.2	Maintenance Schedule	17
6.2.1	Cleaning	19
6.3	Safety Switch	19
6.4	Calibration	19

6.5	After-Sales Service	20
6.6	Recommended Spare Parts and Spare Parts Kit	20
6.7	Element Ageing	20
6.8	Power Adjustment	21
7.0	Repairs and Replacements	22
7.1	Safety Warning - Disconnection from Power Supply	22
7.2	Safety Warning - Refractory Fibre Insulation	22
7.3	Temperature Controller Replacement	22
7.4	Solid-State Relay Replacement	23
7.5	Element Fitting and Replacement	24
7.6	Thermocouple Replacement	25
7.7	Fuse Replacement	25
8.0	Fault Analysis	26
A.	Furnace Does Not Heat Up	26
B.	Product Overheats	27
9.0	Wiring Diagrams	28
9.1	WA-33-32	28
9.2	WA-33-33	29
9.3	WS-01-01	30
9.4	WS-01-02	30
10.0	Fuses and Power Settings	31
10.1	Fuses	31
10.2	Power Settings	31
	User Power Setting Adjustments	32
11.0	Specifications	33
11.1	Environment	33

1.0 Symbols and Warnings

1.1 Switches and Lights



Instrument switch: when the instrument switch is operated the temperature control circuit is energised.



Heat light: the adjacent light glows or flashes to indicate that power is being supplied to the elements.

1.2 General Warnings



DANGER – Electric shock. Read any warning printed next to this symbol.

WARNING: Risk of fatal injury.



DANGER – Hot surface. Read any warning printed next to this symbol.

WARNING: All surfaces of a product may be hot.



DANGER – Read any warning printed next to this symbol.

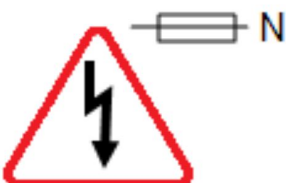

Caution – Double Pole/Neutral Fusing

1.3 Prerequisites to Use

Prior to the commissioning and use of this product, all personnel involved in its installation, operation and maintenance must be deemed competent and have:

- Read and understood the information contained within this manual
- Received the relevant training with regard to safety and operation of the product
- Been provided with the appropriate PPE (Personal Protective Equipment) required for the safe operation of this product

Note: The customer is responsible for ensuring that all of the above conditions are satisfied before the product is commissioned for use.



Note: Unless otherwise specified, the customer is responsible for the installation of this product and the safe connection of any additional equipment and gas or liquid supply lines.

2.0 Installation

2.1 Unpacking & Handling

When unpacking or moving the product, always lift by its base; do not use the door or any other projecting cover or component to support the equipment when moving it. Use a fork lift or pallet truck to move the product; position the product on a level surface and use an adequate number of personnel to safely move the product into position.

Carefully remove any packing material from inside and around the product before use. Avoid damaging the surrounding insulation when removing packing materials.



Note: This product contains Refractory Ceramic Fibre (also known as Alumino Silicate Wool - ASW). For precautions and advice on handling this material see section 7.2.

2.2 Door Counterbalance

Door counterbalance are used as handles to open and close the door. These may be supplied unfitted. If supplied unfitted two grub screws and two door counterbalances should be present. Place the counterbalance into the door shaft as shown in the image below. Fasten the grub screw into the end of the shaft and tighten using an M8 allen key.



2.3 Siting and Setting Up

Place the product on a level surface in a well ventilated area.

Site away from other sources of heat and on a non-flammable surface that is resistant to accidental spillage or hot materials.

The surface on which the equipment is mounted should be stable and not subject to movement or vibrations.

The height of the mounting surface is important to avoid operator strain when loading and unloading samples.

Unless otherwise stated elsewhere in this manual, ensure that there is **at least 150 mm** of free space around the back and sides of the product. Clear space is required above the product to dissipate heat.

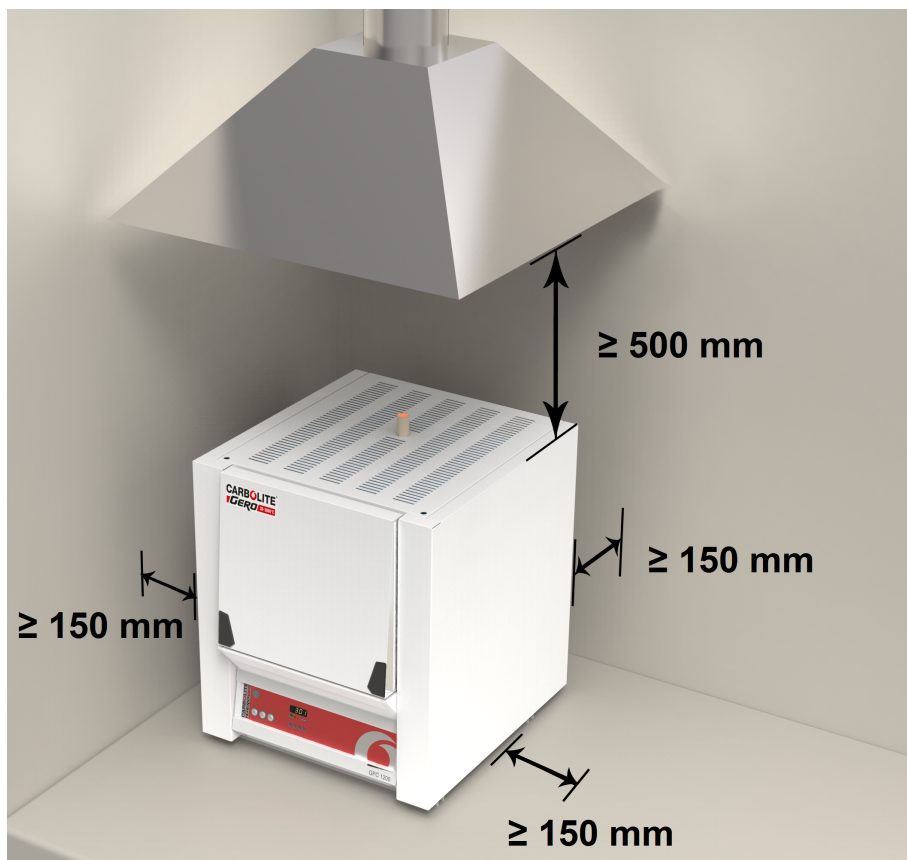

Depending on the application of the product, it may be appropriate to position it under an extraction hood. Ensure the extraction hood is switched on during use.

Ensure that the product is placed in such a way that it can be quickly switched off or disconnected from the electrical supply.



Under no circumstances should any objects be placed on top of the product. Always ensure that any vents on the top of the product are clear of any obstruction. Always ensure all cooling vents and cooling fans (if fitted) are clear of any obstruction.

2.4 Heating Elements

The silicon carbide elements are VERY FRAGILE and are packed separately. Fit them accordingly to the instructions in section 7.0 for element fitting and replacement instructions.

2.5 Electrical Connections



Connection by a qualified electrician is recommended.

The model covered in this manual has three internal circuits and is normally supplied for connection to a three phase power supply. This may be either star or delta, but a product must only be connected to the type and voltage of supply for which it was made. If the product is ordered for a single phase supply, this may be Live to Neutral reversible or non-reversible, or Live to Live.

Check the product rating label before connection. The supply voltage should agree with the voltage on the label and the supply capacity should be sufficient for the current on the label.

The supply should be fused at the next size equal to, or higher than the current on the label. This manual contains a table of the most common fuse ratings.

When the mains cable is factory fitted, internal fuses are also fitted. It is essential that the operator ensures that the product is correctly fused.

Products with a factory fitted supply cable are designed to be wired directly to an isolator or fitted with a line plug.

Products without a factory fitted supply cable require a permanent connection to a fused and isolated supply. The product's electrical access panel should be temporarily removed, and connections made to the internal terminals.

When connecting the product to the power supply, the plug or isolating switch should be accessible, easy to remove, and within reach of the operator.

The supply MUST incorporate an earth (ground).

Electrical Connection Details:

Supply	Terminal Label	Cable Colour	Supply Types	
			Live - Neutral	Reversible or Live-Live
1-phase	L1	Brown	to live	to either power conductor (For USA 200-240V, connect L1)
	N / L2	Blue	to neutral	to the other power conductor (For USA 200-240V, connect L2)
	PE	Green/ Yellow	to earth (ground)	to earth (ground)

2- or 3-phase	L1	Black	to phase 1
	L2	Black	to phase 2
	L3	Black	to phase 3 (except 2-phase)
	N	Light Blue	to neutral (except delta)
	PE	Green/ Yellow	to earth (ground)

Technical Notes

This model has an electronically controlled power limit. Do not attempt to calculate the Amps from the Wattage. High break capacity fuses should be used. Avoid fast-blow fuses and magnetic trip circuit breakers - consult Carbolite Gero if in doubt.

3.0 Temperature Controller

If this product is fitted with a temperature controller, instructions are provided separately.

4.0 Time Switch

4.1 Digital Time Switch - Theben TR 635 top2

The Theben TR 635 top2 is a 7 day digital time switch with 84 memory locations each of which can contain a switching time for any or all or the days in a week. It is battery backed with approximately 10 years power reserve. The shortest switching interval is 1 minute.

A choice of languages is included. There is a real-time clock and a choice of daylight saving rules.

The facia features a digital display and four buttons as shown in the image.

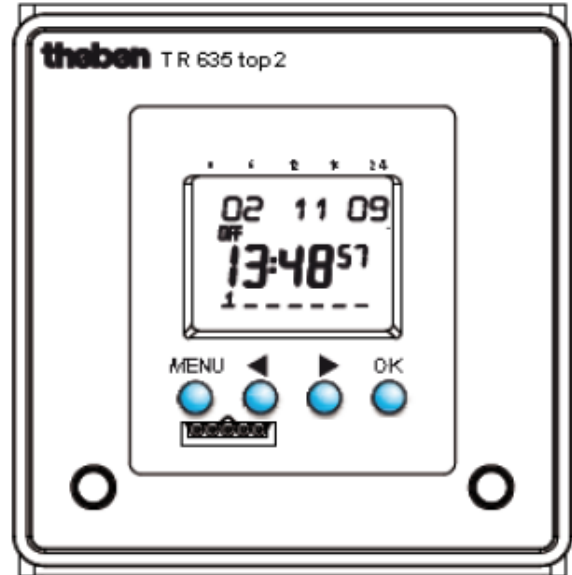

Screen display and keys

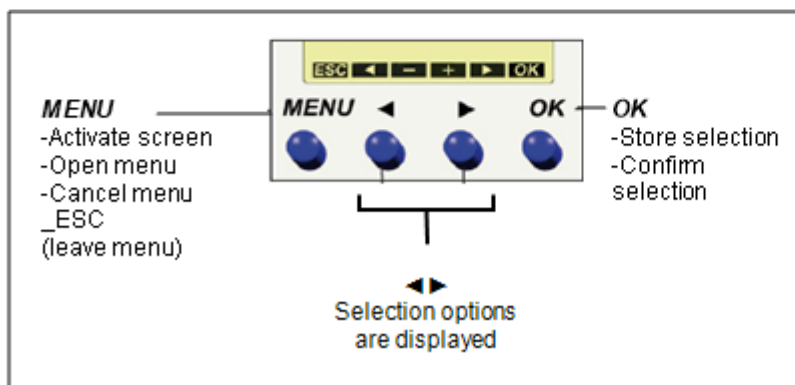
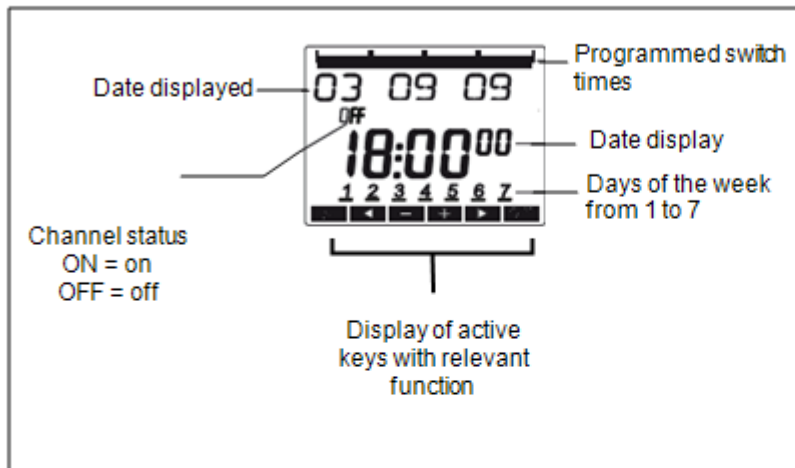

Operating Instructions

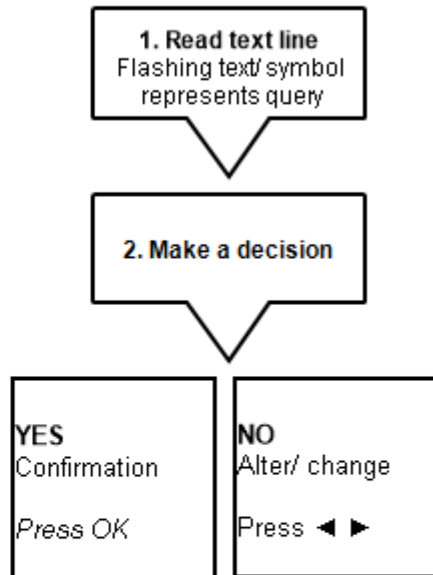

Important Note

In the instructions below, "select" an item means the following:

Press the arrow keys (usually the right) until the item appears on the screen. Then press **OK**.

Reset

To reset press all four buttons simultaneously all stored programs can be retained or deleted. Normally avoid reset except to change the language, as follows.

Press all four buttons simultaneously. Then select the required language.

Set the time and date by pressing the arrow keys and using **OK**. After changing language it may be necessary also to change the daylight saving rules: see the next section.

Setting the Time and Date (and Daylight Saving Rules)

Press the MENU key then use the right arrow key to display TIME/ DATE and then press **OK**. Use the arrow keys and **OK** to set the time and date.

After setting the date, the next display shows the current SU – WI selection. To alter the daylight saving rules, press the arrow keys to select between six different countries or FREE or FIX DATE or NO SU-WI.

If FREE is chosen, a month and date entry sequence is entered: follow the display requests.

Setting a Switch-On or Switch-Off Time

A program entry comprises a function (on or off), a switching time and the days to which it applies.

Press MENU.

PROGRAM is displayed. Press **OK**.

NEW is displayed. Press **OK**.

Use the arrow keys to select ON (for switch on times) or OFF (for switch off times). Press **OK**.

HOUR is displayed. Use the keys to enter hour, minute and confirm by pressing **OK**.

MONDAY is displayed. Select the day required then press **OK**.

COPY is displayed. Press **OK** to copy the switching time to other days or use the arrow key to select SAVE.

Other choices are CHECK, MODIFY, CLEAR or END.

Modifying or deleting a Switch-On or Switch-Off Time

Press MENU.

PROGRAM is displayed. Press **OK**.

NEW is displayed. Use the arrow keys to select CHECK, MODIFY or DELETE. Press **OK** after selecting one of these options. If modifying confirm MODIFY HOUR by pressing **OK**. The first of the switching times is shown. Use the keys to adjust the time and confirm by pressing **OK**.

Once the date and time memories are entered, the time switch automatically obeys them. Note that if the same time is used for an on as an off, off takes priority.

Overriding the Program

To change the present state between on and off, press MENU, select MANUAL. Within the MANUAL choices are PERMANENT ON; PERMANENT OFF; MANUAL ON; TIMER; HOLIDAY; RANDOM & END.

Avoid random, which is irrelevant to furnaces. The holiday feature may be left as an exercise for the reader.

Pulse and Cycle

These features are not required and should be off.



Note: If the furnace is fitted with a CC-T1, instead of starting a program, the time switch will turn the CC-T1 on or off.

5.0 Operation

5.1 Operating Cycle

This product is fitted with an instrument switch which cuts off power to the control circuit.

Connect the product to the electrical supply.

Turn on the instrument switch to activate the temperature controllers. The controllers illuminate and go through a short test cycle.

This product if fitted with a time switch which operates in conjunction with the temperature controller as follows:

Temperature Controller	Time Switch Function	Operation
301 Controller or CC-T1	Time switch cuts power to the temperature controller	Switch on the instrument switch. Set the required setpoint on the temperature controller. Timer in 'OFF' state: furnace does not heat. Timer in 'ON' state: furnace heats to the setpoint.
3016 Programmer or 3008 Programmer	Time switch starts a temperature program	Switch on the instrument switch. Set the required temperature program in the temperature controller. Timer in 'ON' state: the program is started. Timer in 'OFF' state: the program is stopped.

Set the time switch as required.

Set the element over-temperature controller to approximately 100 °C above the maximum or setpoint temperature. The element over-temperature controller protects the heating elements from excessive temperature and if activated is self resetting. When correctly set it may be ignored (see section 5.5).

Chamber Over-Temperature option only. If the digital over-temperature option has not yet been set as required, set and activate it according to the over-temperature controller instructions.

Unless the time switch is switched off, the product starts to heat up according to the controller setpoint or program.

Chamber Over-Temperature option only. If the over-temperature circuit has tripped, an indicator on the over-temperature controller flashes and the heating elements are isolated. Find and correct the cause before resetting the over-temperature controller according to the instructions supplied.

To turn the product off, set the instrument switch to its off position. The controller display will go blank. If the product is to be left unattended, isolate it from the electrical supply.

5.2 Instrument Layout

The controllers are normally laid out as follows, although this may vary:

if controller is a 301 or CC-T1

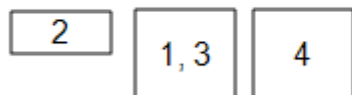

if controller is a 3016 or 3008



1. = Controller/ Programmer
2. = Element over-temperature Controller
3. = Chamber over-temperature Controller (if fitted)
4. = Time Switch

5.3 General Operating Advice



Heating element life is shortened by overheating. Do not leave the product at high temperature when it is not required. The maximum temperature is shown on the product rating label and in section 11.0 towards the back of this manual.



Lightweight ceramic fibre insulation can easily be marked by accidental contact. Some fine cracks may develop in the surface of the insulation due to the progressive shrinkage of the insulation materials. Cracks are not usually detrimental to the functioning or the safety of the product.

Clean up any spillages in the insulation, as these can increase the rate of degradation of the insulation material.

5.4 Operator Safety



This product incorporates a safety switch which interrupts the heating element circuit when the furnace is opened. This prevents the operator touching a live heating element and also prevents the product from heating up if the furnace is left open. The operation of this switch should be checked periodically.



Depending on use, the surfaces in the working chamber and the chamber load may still be very hot after the appliance is switched off. Touching these surfaces may cause burns. Use suitable personal protective equipment or wait until the appliance cools down to ambient temperature.

Before removing a hot object from the product, make sure there is a safe place to put it down. If necessary use tongs, face masks and heat resistant gloves. Heat resistant clothing and face protection can guard against the effects of radiated heat when the furnace is open.

When the product is opened during operation there is considerable radiated heat. Do not keep any flammable objects near the product, nor objects which could be damaged by radiated heat.

5.5 Over-Temperature Control (if fitted)

The product may be fitted with a "chamber over-temperature control", if this has been ordered. The chamber Over-Temperature control stops further heating if an over-temperature condition is reached and heating is not resumed until the system is manually reset. Operating instructions for the over-temperature controller are referred to in section 5.1 and detailed in the controller instructions.

All cupellation furnaces also have an "element over-temperature control" which serves to cut power temporarily to the heating elements if the temperature in the immediate vicinity of the elements is too high. Heating resumes when the temperature drops and manual resetting is not required.

6.0 Maintenance

6.1 General Maintenance

Preventive rather than reactive maintenance is recommended. The type and frequency depends on the product use; the following are recommended.













6.2 Maintenance Schedule

 CUSTOMER

 QUALIFIED PERSONNEL



DANGER! ELECTRIC SHOCK. Risk of fatal injury. Only electrically qualified personnel should attempt these maintenance procedures.

Maintenance Procedure	Method	Frequency				
		Daily	Weekly	Monthly	Bi-Annually	Annually
Safety						
Safety Switch Function	Set a safe temperature above ambient, and open the door to see if the heater light goes out					
Safety Switch Function	Electrical measurement 					
Element Over-Temperature Circuit	Adjust the set-point on the element over-temperature controller to a lower value than the current displayed temperature on the main controller and ensure the heater lights go out.					
Element Over-Temperature Circuit	Electrical measurement 					
Over-Temperature Safety Circuit (if fitted)	Set an over-temperature setpoint lower than the displayed temperature and check for an over-temperature alarm as detailed in this manual					
Over-Temperature Safety Circuit (if fitted)	Electrical measurement 					
Door Plug	Visual inspection, checking the seal and whether it is free of damage					
Door Plug	Replacement where necessary					
Chimney / Extraction	Check and clean if necessary. Empty the collection tray at the rear					
Electrical Safety (external)	Visual check of external cables and plugs					

6.2.1 Cleaning

Soot deposits may form inside the furnace, depending on the process. At appropriate intervals remove these by heating as indicated in the General Operation Notes.



The product's outer surface may be cleaned with a damp cloth. Do not allow water to enter the interior of the case or chamber. Do not clean with organic solvents.

6.3 Safety Switch

When correctly functioning, the safety switch will isolate all live conductors (live and neutral connections) within the heating element circuit(s) when the product door is opened. The safety switch should be checked regularly to ensure that this occurs.

The safety switch should not fail under normal working conditions, however rough handling, exposure to corrosive materials/ environments, or exceptionally frequent use, could compromise the safety system.

Weekly check:

The following check can be carried out by a general operator:

- On the temperature controller, set a safe temperature above ambient. The heater lights should illuminate.
- Open the door and check the heater lights. They should no longer be illuminated.

If the heater lights remain illuminated when the door is open, discontinue use and contact Carbolite Gero Service.

Annual check:

The following checks should be carried out by a qualified electrician, as specified in the "Maintenance Schedule" section of this manual:

- Remove the element access panel and take a voltage measurement from the heating element terminals. Do not attempt to take a reading from the heating element itself as surface oxidation will give an unreliable contact.
- Ensure that power to the heating elements is switched off when the door is opened.

Contact Carbolite Gero Service and discontinue use of the product if it is found that the heating elements are not fully isolated during these checks.

6.4 Calibration

After prolonged use, the controller and/or thermocouple may require recalibration. This is important for processes that require accurate temperature readings or for those that use the product close to its maximum temperature. A quick check using an independent thermocouple and temperature indicator

should be made from time to time to determine whether full calibration is required. Carbolite Gero can supply these items.

Depending on the controller fitted, the controller instructions may contain calibration instructions.

6.5 After-Sales Service

Carbolite Gero Service has a team of Service Engineers who can offer repair, calibration and preventive maintenance of furnace and oven products both at the Carbolite Gero factory and at customers' premises throughout the world. A telephone call or email often enables a fault to be diagnosed and the necessary parts to be despatched.

In all correspondence please quote the serial number and model type given on the rating label of the product. The serial number and model type are also given on the back of this manual when supplied with the product.

Carbolite Gero Service and Carbolite Gero contact information can be found on the back page of this manual.

6.6 Recommended Spare Parts and Spare Parts Kit

Carbolite Gero can supply individual spare parts or a kit of the items most likely to be required. Ordering a kit in advance can save time in the event of a breakdown.

Each kit consists of one thermocouple, one sheath, one solid-state relay, one door insulation piece, a set of elements, a set of element clips and a set of braids and clips. Individual spare parts are also available.

When ordering spare parts please quote the model details as requested above.

6.7 Element Ageing

Silicon carbide elements gradually increase in resistance with use; a process known as ageing. Their heating power reduces correspondingly. To ensure sufficient power to the product, it may be necessary to adjust the power limit and, ultimately, replace the elements - taking care to readjust the power limit.

Note: A clamp meter should be used when adjusting the power limit to ensure that the current is not inadvertently increased beyond safe limits. Please contact Carbolite Gero Service for guidance on safe current limits.

If the product does not reach temperature, or is slow, check the power limit setting and increase the value by 5%. It is recommended to make a note of the new settings and the date of the adjustment in section 10.0. Increase the power limit in steps of 5% until the product regains its original performance.

If the power limit is set to 100% a new set of heating elements is required.

Please note: it is not possible to use the cold resistance of the element as a measure of ageing as the cold resistance is not an accurate indicator of hot resistance. Hot resistance is used to calculate furnace power.

See the controller instructions for how to adjust the controller. Always record the setting when first making an adjustment. If new elements are fitted, return the adjustments to the original value. A table of standard power limits is given in section 10.0.

6.8 Power Adjustment

The product's control system incorporates electronic power limiting. Power is supplied to the elements in bursts of approximately 0.33 seconds duration. This prevents overheating of the elements. The power limit is programmed into the product controller.

A table of standard power limits is supplied with new products, it is given in section 10.0

7.0 Repairs and Replacements

7.1 Safety Warning - Disconnection from Power Supply



Immediately switch the product off in the event of unforeseen circumstances (e.g. large amount of smoke). Allow the product to return to room temperature before inspection.



Always ensure that the product is disconnected from the electrical supply before repair work is carried out.

Caution: Double pole/neutral fusing may be used in this product.

7.2 Safety Warning - Refractory Fibre Insulation



Insulation made from High Temperature Insulation Wool Refractory Ceramic Fibre, better known as (Alumina silicate wool - ASW).

This product contains **alumino silicate wool** products in its thermal insulation. These materials may be in the form of blanket or felt, formed board or shapes, slab or loose fill wool.

Typical use does not result in any significant level of airborne dust from these materials, but much higher levels may be encountered during maintenance or repair.

Whilst there is no evidence of any long term health hazards, it is strongly recommended that safety precautions are taken whenever the materials are handled.

Exposure to fibre dust may cause respiratory disease.

When handling the material, always use approved respiratory protection equipment (RPE- eg. FFP3), eye protection, gloves and long sleeved clothing.

Avoid breaking up waste material. Dispose of waste in sealed containers.

After handling, rinse exposed skin with water before washing gently with soap (not detergent). Wash work clothing separately.

Before commencing any major repairs it is recommended to make reference to the European Association representing the High Temperature Insulation Wool industry (www.ecfia.eu).

Further information can be provided on request. Alternatively, Carbolite Gero Service can quote for any repairs to be carried out either on site or at the Carbolite Gero factory.

7.3 Temperature Controller Replacement

Refer to the controller instructions for more information on how to replace the temperature controller.

7.4 Solid-State Relay Replacement



Disconnect the product from the power supply and remove the appropriate cover as given above.

1. Make a note of the wire connections to the solid state relay, then disconnect them.
2. Remove the solid state relay from the base panel or aluminium plate.
3. Replace and reconnect the solid state relay ensuring that the bottom of it has good thermal contact with the base panel or aluminium plate.
4. Replace the access panel.

7.5 Element Fitting and Replacement

Replacements: see section 6.7. If at any time the power limit has been increased, reset it to its original value (see section 10.0 at the back of this manual for the original value).

New elements must not be mixed with aged elements. If a single heating element fails within an element circuit containing aged elements, then all heating elements on that circuit should be replaced. It may not be necessary to replace all heating elements within a furnace, however the configuration of elements varies between products. If required, please contact Carbolite Gero Service for advice.

Please provide the serial number of the furnace with all enquiries.



Disconnect the product from the electrical supply.

Remove the side panels to gain access to the element connections.

Remember that the elements are fragile and expensive and that they can be damaged by contamination: handle them with care and keep them clean.

First Fitting: The product is supplied with all element connection braids in position, except for 3 off loose braids. Insert the elements as explained below and connect the fitted braids to the adjacent element ends. Connect the loose braids in pairs to the unconnected ends, on the same side of the product as the element power terminals.

Replacements: Replace each element in turn. Release the clips using the tool provided. Move the braids and carefully withdraw each element: it may be necessary to remove the element sleeve with the element.

Carefully insert the new element, locating the sleeves as shown. Sleeves are fragile: it may be necessary to use new ones. Ensure that the element hot zone is equally placed within the chamber.

Connect the braids. Check that the braids cannot touch each other or the case and that there is no short circuit to earth.

If aged elements have been replaced, reset the products power limit.

Refit the panels and test the product.

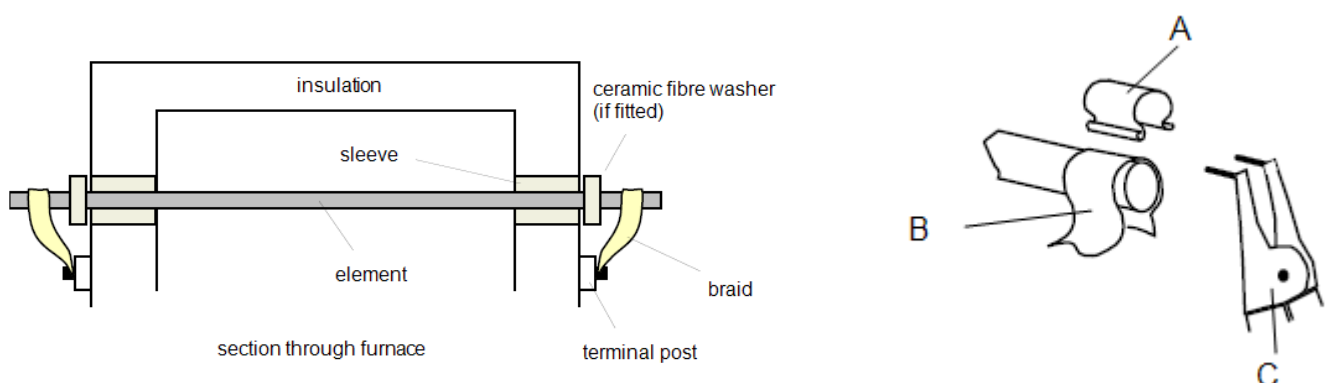

7.6 Thermocouple Replacement



Disconnect the product from the power supply. Remove the appropriate panel to gain access to the thermocouple connections. Make a note of the thermocouple connections.

Thermocouple cable colour codings are:

thermocouple leg	colour
positive (type R)	orange
negative	white

Disconnect the thermocouple from its terminal block; retain any porcelain spacers.

Withdraw the thermocouple from its sheath and remove any broken bits of thermocouple.

Re-assemble with a new thermocouple observing the colour coding.

Refit the element access panel.

7.7 Fuse Replacement

Fuses are marked on the wiring diagram with type codes, e.g. F1, F2. For more information on fuses refer to section 10.0.

Depending on model and voltage, the different fuse types may or may not be fitted.

If any fuse has failed, it is advisable for an electrician to check the internal circuits.

Replace any failed fuses with the correct type. For safety reasons do not fit larger capacity fuses without first consulting Carbolite Gero.

The fuses are located at the cable entry point. Remove the back panel or control box back panel to gain access to the fuses.

8.0 Fault Analysis

A. Furnace Does Not Heat Up					
1.	The HEAT light is ON	▶	The heating element has failed	▶	Check also that the SSR is working correctly
2.	The HEAT light is OFF	▶	The controller shows a very high temperature or code such as S.br	▶	The thermocouple has broken or has a wiring fault
		▶	The controller shows a low temperature	▶	The door switch(es) (if fitted) may be faulty or need adjustment
				▶	The contactor/relay (if fitted) may be faulty
				▶	The heater switch (if fitted) may be faulty or need adjustment
				▶	The SSR could be failing to switch on due to internal failure, faulty logic wiring from the controller, or faulty controller
		▶	There are no lights glowing on the controller	▶	Check the supply fuses and any fuses in the furnace control compartment
				▶	The controller may be faulty or not receiving a supply due to a faulty switch or a wiring fault.

B. Product Overheats					
1.	Product only heats up when the instrument switch is ON	▶	The controller shows a very high temperature	▶	The controller is faulty
		▶	The controller shows a low temperature	▶	The thermocouple may be faulty or may have been removed out of the heating chamber
				▶	The thermocouple may be connected the wrong way around
				▶	The controller may be faulty
2.	Product heats up when the instrument switch is OFF	▶	The SSR has failed "ON"	▶	Check for an accidental wiring fault that could have overloaded the SSR

9.0 Wiring Diagrams

9.1 WA-33-32

Connections below show 3-phase +N with indirect safety switches and E/ temperature control.

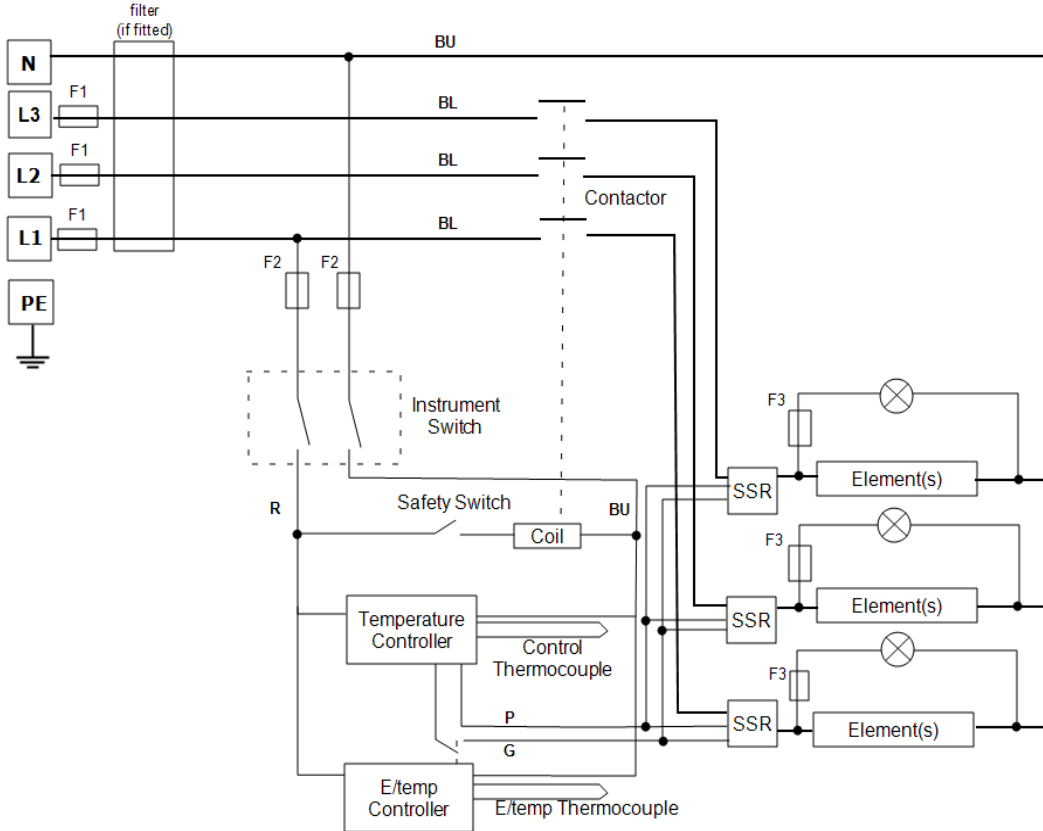

9.2 WA-33-33

Connections below show 3-phase +N with indirect safety switches, over-temperature and E/ temperature control.

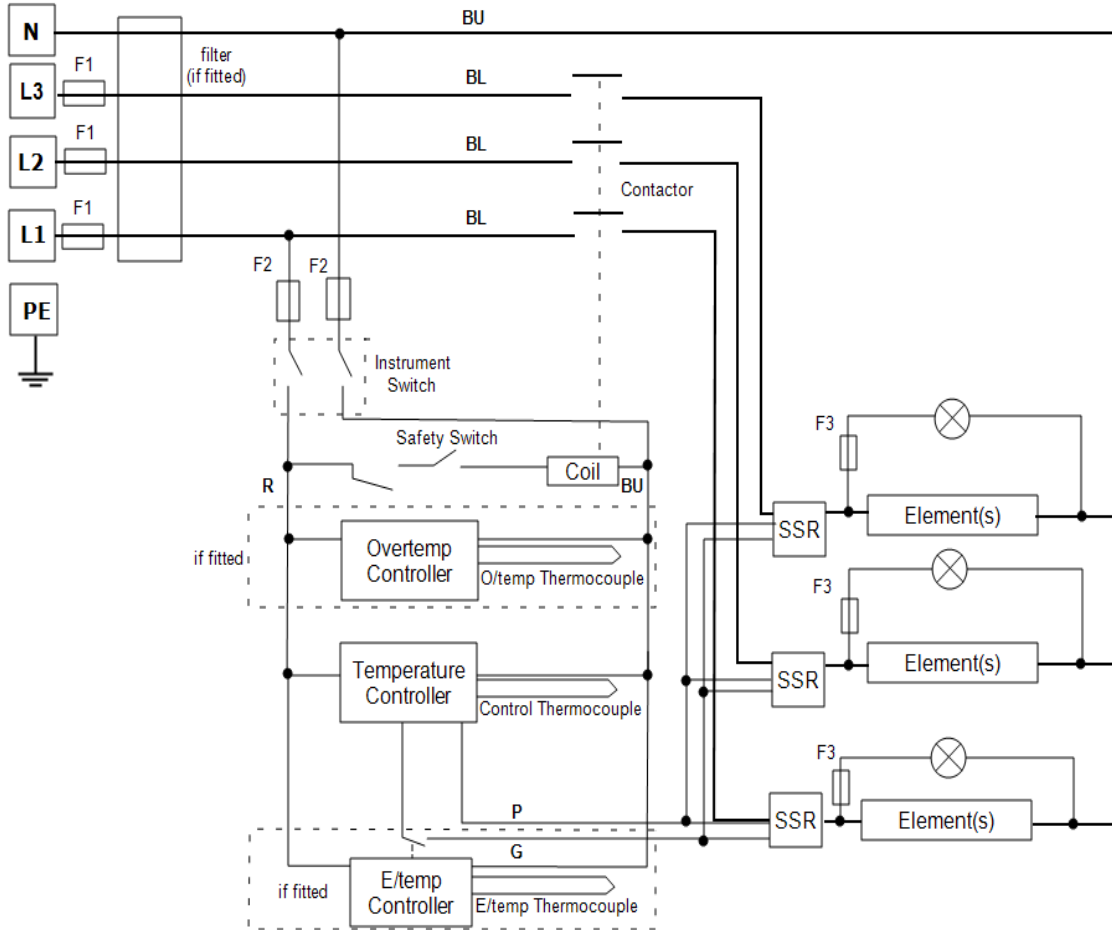

9.3 WS-01-01

The time switch motor circuit is connected to the supply side of the instrument switch. The volt-free contacts are in series with the instrument switch.

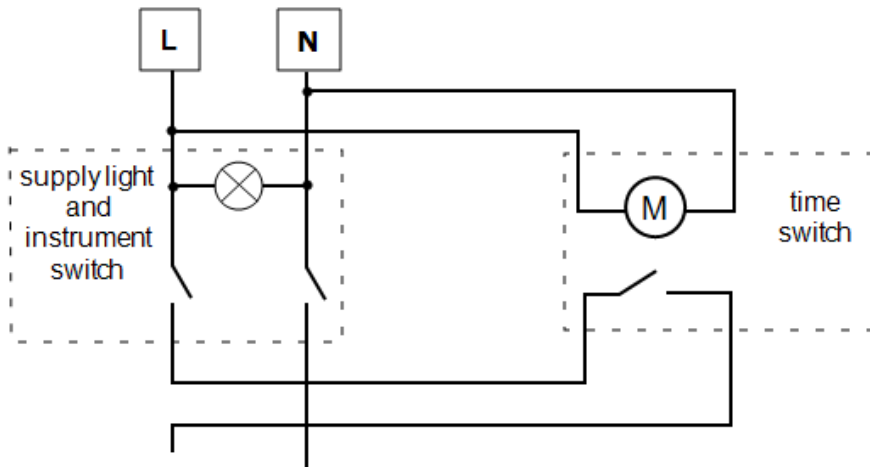

9.4 WS-01-02

The time switch motor circuit is connected to the supply side of the instrument switch. The volt-free contacts connect to digital inputs on the programmer; the programmer is configured to start the program when the time switch comes on, and to reset when it goes off.

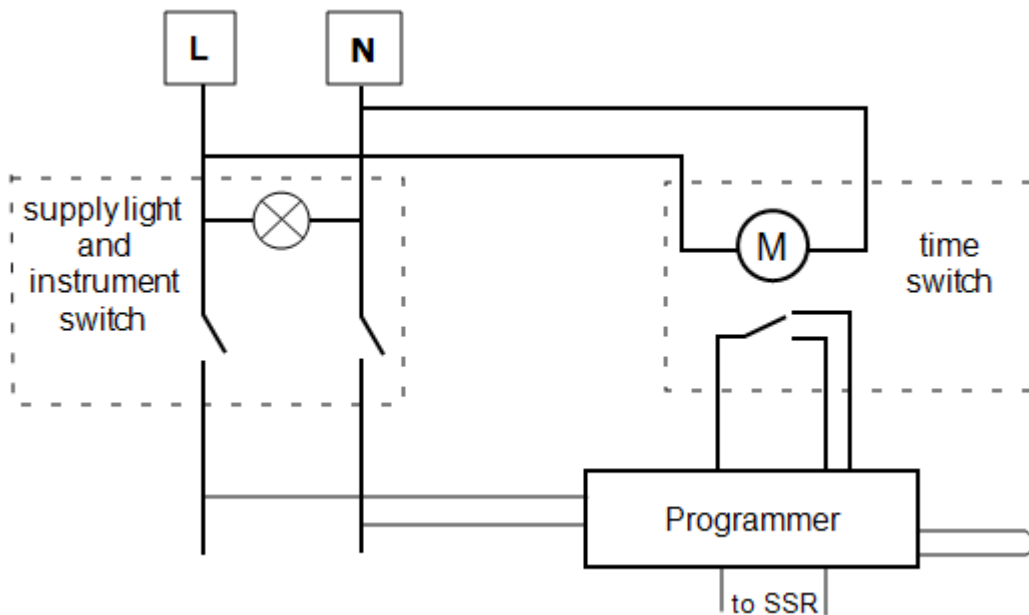

10.0 Fuses and Power Settings

10.1 Fuses

F1 - F3: Refer to the circuit diagrams.

F1	Internal Supply Fuses	Fitted if supply cable fitted. Fitted on board to some types of EMC filter.	38 mm x 10 mm type F fitted on EMC filter circuit board(s)
F2	Auxiliary Circuit Fuses	Fitted on board to some types of EMC filter. May be omitted up to 25 Amp/phase supply rating.	2 Amps glass type F On board: 20 mm x 5 mm Other: 32 mm x 6 mm
F3	Heat Light Fuses	May be omitted up to 25 Amp/phase supply rating.	2 Amps glass type F 32 mm x 6 mm
	Customer Fuses	Required if no supply cable fitted. Recommended if cable fitted.	See rating label for current; See table below for fuse rating.

Model	Phases	Volts	Supply Fuse Rating
CF 60B	3-phase + N	440-480	60 A (per phase)
CF 60B	3-phase + N	380/220 - 415/240	63 A
CF 60B	3-phase Delta	208-240	125 A

10.2 Power Settings

The power limit settings (parameter OP.Hi) for this model are voltage dependant. The figures represent the maximum percentage of time that controlled power is supplied to the elements. Do not attempt to "improve performance" by setting a value higher than the recommended values. To adjust the parameter refer to the "Changing the Maximum Output Power" of the control section of the manual.

Volts	200 V	208 V	220 V 380 V	230 V 400 V	240 V 415 V	440 V	480V
Power (%)	78	72	64	59	54	54	46

User Power Setting Adjustments		
Date	% Power	Comments

Note: If a new set of elements are fitted then return the power settings to the original value.

Please refer to the rating label for product specific information.

11.0 Specifications

Carbolite Gero reserves the right to change the specification without notice.

Model	Max Temp (°C)	Max Power (kW)	Chamber Size (mm)			Net Weight (kg)
			H	W	D	
Cupellation Furnaces heated by silicon carbide elements.						
CF 60B	1200	31	250	400	650	306

11.1 Environment

The models listed in this manual contain electrical parts and should be stored and used in indoor conditions as follows:

Temperature: 5 °C - 40 °C

Relative humidity: Maximum 80 % up to 31 °C decreasing linearly to 50 % at 40 °C

ProductLabel

The products covered in this manual are only a small part of the wide range of ovens, chamber furnaces and tube furnaces manufactured by Carbolite Gero for laboratory and industrial use. For further details of our standard or custom built products please contact us at the address below, or ask your nearest stockist.

For preventive maintenance, repair and calibration of all furnace and oven products, please contact:

Carbolite Gero Service

Telephone: + 44 (0) 1433 624242

Fax: +44 (0) 1433 624243

Email: ServiceUK@carbolite-gero.com

Carbolite Gero Ltd,

Parsons Lane, Hope, Hope Valley,
S33 6RB, England.

Telephone: + 44 (0) 1433 620011

Fax: + 44 (0) 1433 621198

Email: Info@carbolite-gero.com

www.carbolite-gero.com

CARBOLITE
GERO 30-3000°C